

Natural Sciences Admissions Assessment
Cambridge NSAA 2022 Solutions
Section 1

These solutions are provided by Dr Leonardo.
Visit my-academics.com/nsaa for more notes and online private tutoring.

PART A Mathematics

1 Which one of the following is a simplification of

$$y \left(\frac{3x^{\frac{1}{2}}z}{y^3} \right)^2 =$$

A $\frac{3xz^2}{y^4}$

B $\frac{3xz^2}{y^5}$

C $\frac{9x^{\frac{1}{2}}z^2}{y^5}$

D $\frac{9xz^2}{y^4}$

E $\frac{9xz^2}{y^5}$

F $\frac{9x^{\frac{5}{2}}z^2}{y^5}$

$$= \cancel{y} \cdot \frac{3^2 \cdot x \cdot z^2}{\cancel{y^6}^5}$$

$$= \frac{9xz^2}{y^5}$$

- 2 Triangle PQR has a right angle at Q .

The point T lies on QR such that $QT = \frac{1}{4}QR$

$$PT = 6 \text{ cm}$$

$$PR = 12 \text{ cm}$$

What is the length of QT , in cm?

- A 2
 B $2\sqrt{3}$
 C $\frac{3}{2}\sqrt{2}$
 D $\frac{6}{5}\sqrt{5}$
 E $\frac{2}{7}\sqrt{21}$

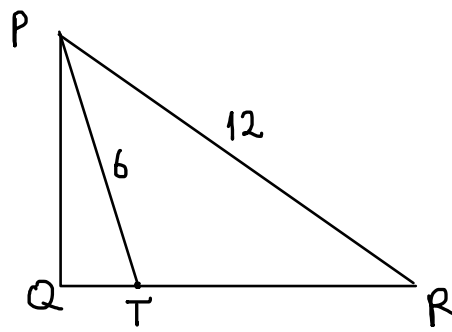

$$QR = 4QT$$

PYTHAGORA'S THEOREM:

$$6^2 = PQ^2 + QT^2$$

$$PQ^2 = 36 - QT^2$$

$$12^2 = PQ^2 + QR^2$$

$$144 = 36 - QT^2 + (4QT)^2$$

$$108 = 15QT^2$$

$$QT = \frac{6\sqrt{5}}{5}$$

- 3 Find the complete set of values of x that satisfy the inequality

$$\frac{3}{4}(5-x) - \frac{1}{2}(6-x) - x < 0$$

A $x < \frac{1}{3}$

B $x > \frac{1}{3}$

C $x < \frac{3}{5}$

D $x > \frac{3}{5}$

E $x < \frac{3}{4}$

F $x > \frac{3}{4}$

G $x < \frac{3}{2}$

H $x > \frac{3}{2}$

$$\frac{15}{4} - \frac{3}{4}x - 3 + \frac{1}{2}x - x < 0$$

$$-\frac{5}{4}x < -\frac{3}{4} \quad / \cdot \left(-\frac{4}{5}\right)$$

Careful: the inequality sign changes when multiplying both sides with a negative number

$$x > -\frac{3}{4} \cdot \left(-\frac{4}{5}\right)$$

$$x > \frac{3}{5}$$

4 I have two fair dice, X and Y, each of which has six sides.

The faces on X are labelled 1, 1, 2, 3, 4, 5.

The faces on Y are labelled 2, 3, 4, 5, 6, 6.

I roll the dice together and calculate my total score by adding the number rolled on X to the number rolled on Y.

What is the probability that my total score is greater than 9?

A $\frac{1}{4}$

B $\frac{1}{6}$

C $\frac{1}{9}$

D $\frac{5}{12}$

E $\frac{5}{36}$

First row - dice X values. First Column - dice Y values. Middle = their sum.

	1	1	2	3	4	5
2	3	3	4	5	6	7
3	4	4	5	6	7	8
4	5	5	6	7	8	9
5	6	6	7	8	9	10
6	7	7	8	9	10	11
6	7	7	8	9	10	11

$$P(\text{SUM} > 9) = \frac{\text{No OF OUTCOMES} > 9}{\text{TOTAL No}} = \frac{5}{36}$$

5 Rob keeps a record of what he earns each day.

On Monday, he earned 50% less than he earned on Sunday.

On Tuesday, he earned 20% more than he earned on Monday.

On Wednesday, he earned 30% less than he earned on Tuesday.

On Wednesday, he earned £84.

How much did Rob earn on Sunday?

A £15.12

B £35.28

C £117.60

D £200

E £210

F £300

G £1200

$$M = 0.5S$$

$$T = 1.2M = 1.2 \cdot 0.5S = 0.6S$$

$$W = 0.7T = 0.7 \cdot 0.6S = 0.42S$$

$$84 = 0.42S$$

$$S = \frac{84}{0.42} = \frac{8400}{42} = 200$$

6 The n^{th} term of a sequence T is $(n - 3)^2$, where n is a positive integer.

The n^{th} term of another sequence V is $3n + p$, where p is a constant and n is a positive integer.

The 10th term in T is equal to twice the 5th term in V.

What is the 4th term in V?

A -16

B 4

C 16.5

D 21.5

E 31

F 46

G 95

$$10^{\text{th}} \text{ TERM IN T} = 2 \times 5^{\text{th}} \text{ TERM IN V}$$

$$(10 - 3)^2 = 2 \cdot (3 \cdot 5 + p)$$

$$49 = 30 + 2p$$

$$p = 9.5$$

$$4^{\text{th}} \text{ TERM IN V} = 3 \cdot 4 + 9.5 = 21.5$$

7 Which one of the following is a simplification of

$$\frac{5x^2 - 17x - 12}{25x^2 - 9} \div \frac{x^2 + x - 12}{x^2 - x - 6} =$$

A $\frac{(x-4)(x+2)}{(x-3)(x+4)}$

B $\frac{(x-3)(x+2)}{(5x-3)(x+3)}$

C $\frac{(x-4)(x+2)}{(5x-3)(x+4)}$

D $\frac{(x-4)(x-3)}{(5x-3)(x-6)}$

E $\frac{(x+2)}{(5x+3)}$

F $\frac{(x+4)(x-6)}{(5x+3)(x+2)}$

G $\frac{(x-3)(x+2)}{(5x+3)(x+3)}$

$$= \frac{5x^2 + 20x - 3x - 12}{(5x-3)(5x+3)} \cdot \frac{x^2 - x - 6}{x^2 + x - 12} =$$

$$= \frac{5x(x+4) - 3(x+4)}{(5x-3)(5x+3)} \cdot \frac{x^2 + 2x - 3x - 6}{x^2 + 4x - 3x - 12} =$$

$$= \frac{\cancel{5x-3}(x+4)}{\cancel{5x-3}(5x+3)} \cdot \frac{x(x+2) - 3(x+2)}{x(x+4) - 3(x+4)} =$$

$$= \frac{x+4}{5x+3} \cdot \frac{\cancel{x-3}(x+2)}{(x+4)\cancel{x-3}}$$

8 S is a list of six numbers:

$$1, 2, x, x + 1, x + 1, 15 \quad \text{where } 2 \leq x \leq 14$$

The mean of S is one more than the median of S.

What is the value of x ?

- A $2\frac{2}{3}$
- B $3\frac{2}{3}$
- C $4\frac{2}{3}$
- D $5\frac{2}{3}$
- E $6\frac{2}{3}$

MEDIAN = MIDDLE POSITION

x & $x+1$ SHARE THE MID POSITION SO

$$\text{MEDIAN} = \frac{x + (x+1)}{2} = x + \frac{1}{2}$$

$$\text{MEAN} = \frac{1+2+x+(x+1)+(x+1)+15}{6} = \frac{3x+20}{6}$$

$$\text{MEAN} = \text{MEDIAN} + 1$$

$$\frac{3x+20}{6} = x + \frac{1}{2} + 1$$

$$3x+20 = 6x+9$$

$$x = \frac{11}{3} = 3\frac{2}{3}$$

9 A rectangle PQRS has length $(2x - 1)$ cm and width $(x + 1)$ cm as shown on the diagram.

A larger rectangle is made by adding 3 cm to both the length and the width of PQRS, as shown.

The larger rectangle has an area of 360 cm^2 .

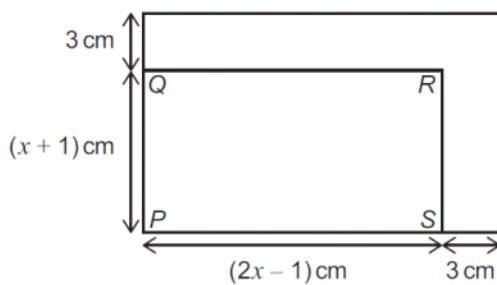

[diagram not to scale]

$$(x+1+3) \cdot (2x-1+3) = 360$$

$$(x+4) \cdot (2x+2) = 360 \quad / \cdot 2$$

$$(x+4)(x+1) = 180$$

$$x^2 + 5x + 4 = 180$$

$$x^2 + 5x - 176 = 0$$

$$x^2 + 16x - 11x - 176 = 0$$

$$x(x+16) - 11(x+16) = 0$$

$$(x-11)(x+16) = 0$$

$$x = 11 \quad \text{or } x = -16$$

What is the ratio of PQ to PS?

- A 1:2
- B 4:7
- C 5:8
- D 7:11
- E 10:17
- F 17:31

$$\frac{PQ}{PS} = \frac{11+1}{2 \cdot 11 - 1} = \frac{12}{21} = \frac{4}{7}$$

- 10 t is inversely proportional to the square of w .

t and w are positive numbers.

$t = 36$ when $w = 2 \times 10^{-2}$

What is the value of w when $t = 100$?

A 1.2×10^{-4}

B 1.2×10^{-2}

C 1.44×10^{-6}

D 1.44×10^{-3}

E $\frac{10}{3} \times 10^{-4}$

F $\frac{10}{3} \times 10^{-2}$

G 7.2×10^{-6}

H 7.2×10^{-3}

$$t \propto \frac{1}{w^2}$$

$$\frac{t_1}{t_2} = \frac{\frac{1}{w_1^2}}{\frac{1}{w_2^2}} = \frac{w_2^2}{w_1^2}$$

$$\Rightarrow \frac{36}{100} = \frac{w_2^2}{(2 \cdot 10^{-2})^2} \quad \sqrt{\quad}$$

$$\frac{6}{10} = \frac{w_2}{2 \cdot 10^{-2}}$$

$$w_2 = \frac{12 \cdot 10^{-2}}{10} = 1.2 \cdot 10^{-2}$$

- 11 PQRS is a trapezium as shown.

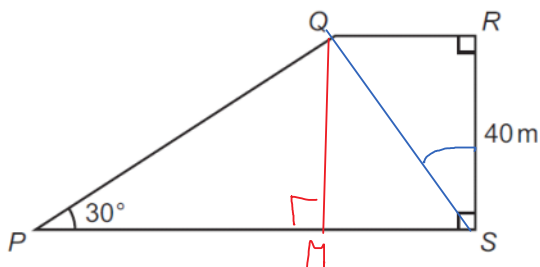

[diagram not to scale]

$$\tan RSQ = \frac{5}{8}$$

$$\frac{RQ}{RS} = \frac{5}{8}$$

$$RQ = \frac{5}{8} \cdot RS = \frac{5}{8} \cdot 40 = 25$$

$$MS = RQ = 25$$

$$MQ = RS = 40$$

$$\tan RSQ = \frac{5}{8}$$

What is the length of PS, in metres?

- A 45
- B 65
- C 80
- D 120
- E $25 + \frac{40\sqrt{3}}{3}$
- F $40 + \frac{64\sqrt{3}}{3}$
- G $25 + 40\sqrt{3}$
- H $64 + 40\sqrt{3}$

$$\tan 30^\circ = \frac{MQ}{MP}$$

$$\frac{\sqrt{3}}{3} = \frac{40}{MP}$$

$$MP = 40 \cdot \frac{3}{\sqrt{3}} = 40\sqrt{3}$$

$$PS = MP + MS = 25 + 40\sqrt{3}$$

If you cannot remember the value of $\tan 30$, there is another method in which the triangle PQM is completed into an equilateral triangle.

- 12 A cyclist rides along a track to the top of a hill then immediately turns around and descends along the same track to her starting point.

She takes 40 minutes at an average speed of 12 km h^{-1} to reach the top.

Her average speed for the whole journey is 15 km h^{-1} .

What is the average speed of her descent?

- A 16 km h^{-1}
 B 18 km h^{-1}
 C 20 km h^{-1}
 D 24 km h^{-1}
 E 30 km h^{-1}

The track distance s is the same for ascent and descent.

$$s = v_{\text{ASCENT}} t_{\text{ASCENT}}$$

$$\begin{aligned} s &= 12 \text{ km/h} \cdot 40 \text{ min} \\ &= 12 \text{ km/h} \cdot \frac{2}{3} \text{ h} \\ &= 8 \text{ km} \end{aligned}$$

The total distance travelled is $2s$.

$$2s = v_{\text{AVE}} t_{\text{TOTAL}}$$

$$16 \text{ km} = 15 \text{ km/h} \cdot t_{\text{TOTAL}}$$

$$t_{\text{TOTAL}} = \frac{16}{15} \text{ h}$$

$$t_{\text{TOTAL}} = t_{\text{ASCENT}} + t_{\text{DESCENT}}$$

$$t_{\text{DESCENT}} = \frac{16}{15} - \frac{2}{3} = \frac{2}{5} \text{ h}$$

$$v_{\text{DESCENT}} = \frac{s}{t_{\text{DESCENT}}} = \frac{8}{\frac{2}{5}} = 20 \text{ km/h}$$

- 13 A solid cylinder has radius r cm and height h cm.

A cube has side length $3r$ cm.

The total surface area of the cylinder is equal to four times the total surface area of the cube.

Which of the following is an expression for h in terms of r ?

- A $\left(\frac{18}{\pi} - 2\right)r$
 B $\left(\frac{18}{\pi} - 1\right)r$
 C $\frac{27r}{\pi}$
 D $\left(\frac{27}{\pi} - 1\right)r$
 E $\left(\frac{27}{4\pi} - 1\right)r$
 F $\frac{108r}{\pi}$
 G $\left(\frac{108}{\pi} - 1\right)r$
 H $\left(\frac{108}{\pi} - \frac{1}{2}\right)r$

SURFACE CYLINDER = 4 x SURFACE CUBE

$$2 \cdot \pi r^2 + 2\pi r h = 4 \cdot 6 \cdot (3r)^2$$

$$2\pi r^2 + 2\pi r h = 216r^2$$

$$2\pi h = 216r - 2\pi r \quad /: 2\pi$$

$$h = \frac{108}{\pi} r - r$$

- 14 Consider the equation $2x^2 + 4x + c = 0$, where c is a constant.

The positive difference between the roots of this equation is $\sqrt{10}$.

What is the value of c ?

- A -5
- B -4.5
- C -3
- D -0.5
- E 0.75
- F 8

FOR $ax^2 + bx + c = 0$, THE ROOTS ARE

$$x_1 = \frac{-b + \sqrt{b^2 - 4ac}}{2a} \quad \& \quad x_2 = \frac{-b - \sqrt{b^2 - 4ac}}{2a}$$

SO $x_1 - x_2 = 2 \cdot \frac{\sqrt{b^2 - 4ac}}{2a}$

THEREFORE $\sqrt{10} = \frac{\sqrt{4^2 - 4 \cdot 2 \cdot c}}{2}$

$$2\sqrt{10} = \sqrt{16 - 8c} \quad /^2$$

$$40 = 16 - 8c$$

$$c = -3$$

- 15 The variables x and y are related by the equation:

$$x = 5 - \frac{2y^3 + 1}{1 - 2y^3}$$

Which of the following is a rearrangement to make y the subject?

A $y = \sqrt[3]{\frac{x-4}{8x-48}}$

B $y = \sqrt[3]{\frac{x-6}{8x-32}}$

C $y = \sqrt[3]{\frac{x-2}{x-6}}$

D $y = \sqrt[3]{\frac{x-3}{x-4}}$

E $y = \sqrt[3]{\frac{x-4}{2x-12}}$

F $y = \sqrt[3]{\frac{x-6}{2x-8}}$

$$\frac{2y^3 + 1}{1 - 2y^3} = 5 - x \quad / \cdot (1 - 2y^3)$$

$$2y^3 + 1 = 5 - x - 10y^3 + 2xy^3$$

$$12y^3 - 2xy^3 = 4 - x$$

$$y^3(12 - 2x) = 4 - x$$

$$y = \sqrt[3]{\frac{4-x}{12-2x}} = \sqrt[3]{\frac{x-4}{2x-12}}$$

16 PQR is a triangle as shown.

S and T are points on the sides PQ and PR .

ST is parallel to QR .

$$PS = 3 \text{ cm}$$

$$ST = x \text{ cm}$$

$$QS = (x + 2) \text{ cm}$$

$$QR = (2x + 1) \text{ cm}$$

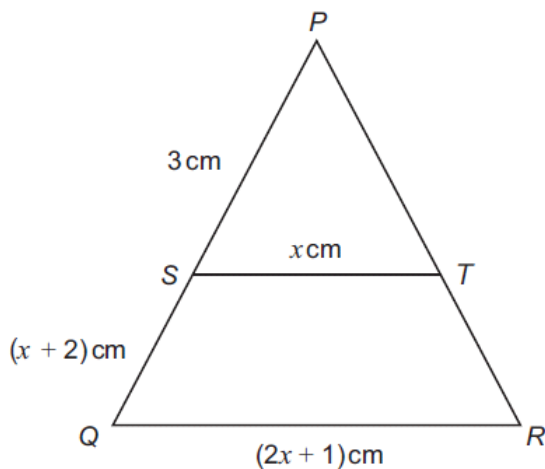

[diagram not to scale]

What is the length, in cm, of QR ?

A $2 + \sqrt{5}$

B $2 + \sqrt{13}$

C $5 + 2\sqrt{7}$

D $5 + 2\sqrt{11}$

E 7

F 9

USE SIMILAR TRIANGLES.

$$\frac{PS}{PQ} = \frac{ST}{QR}$$

$$\frac{3}{3+(x+2)} = \frac{x}{2x+1}$$

$$3 \cdot (2x+1) = x(x+5)$$

$$6x+3 = x^2+5x$$

$$x^2 - x - 3 = 0$$

$$x = \frac{1 \pm \sqrt{1^2 - 4 \cdot 1 \cdot (-3)}}{2}$$

$$x = \frac{1 \pm \sqrt{13}}{2}$$

$$x > 0 \text{ so } x = \frac{1 + \sqrt{13}}{2}$$

$$QR = 2x+1 = 1 + \sqrt{13} + 1 = 2 + \sqrt{13}$$

- 17 Three different numbers are chosen at random from $\sqrt{1}, \sqrt{2}, \sqrt{3}, \sqrt{4}, \sqrt{5}$.

What is the probability that the three numbers form the three sides of a right-angled triangle?

- A $\frac{1}{15}$
- B $\frac{1}{10}$
- C $\frac{3}{10}$
- D $\frac{1}{3}$
- E $\frac{2}{5}$**
- F $\frac{2}{3}$
- G $\frac{4}{5}$

TOTAL NO COMBINATIONS $\cdot 5 \cdot 4 \cdot 3 = 60$

PYTHAGORA: $c^2 = a^2 + b^2$

POSSIBLE TRIANGLE VALUES: $\sqrt{1}, \sqrt{2}, \sqrt{3}$

$\sqrt{1}, \sqrt{3}, \sqrt{4}$

$\sqrt{1}, \sqrt{4}, \sqrt{5}$

$\sqrt{2}, \sqrt{3}, \sqrt{5}$

} 4 POSSIBILITIES

HOWEVER ORDER DOESN'T MATTER

E.G. $\sqrt{1}, \sqrt{2}, \sqrt{3}$ CAN ALSO BE $\sqrt{1}, \sqrt{3}, \sqrt{2}$; $\sqrt{2}, \sqrt{1}, \sqrt{3}$; $\sqrt{2}, \sqrt{3}, \sqrt{1}$; $\sqrt{3}, \sqrt{1}, \sqrt{2}$; $\sqrt{3}, \sqrt{2}, \sqrt{1}$

↳ 6 DIFFERENT ORDERS

NO TRIANGLE COMBINATIONS = 4 POSSIBILITIES \times 6 ORDERS = 24

$$\text{PROBABILITY} = \frac{\text{NO TRIANGLE COMBINATIONS}}{\text{NO TOTAL COMBINATIONS}} = \frac{24}{60} = \frac{2}{5}$$

- 18 P, Q and R are regular polygons.

Q has three times as many sides as P.

An interior angle of Q is 10° larger than an interior angle of P.

R has twice as many sides as Q.

SUM OF ANGLES OF A POLYGON = $(n-2) \cdot 180^\circ$

ANGLE OF A REGULAR POLYGON $\alpha_n = \frac{(n-2) \cdot 180^\circ}{n}$

How much larger is an interior angle of R than an interior angle of Q, in degrees?

- A $2\frac{1}{2}$**
- B 5
- C $6\frac{2}{3}$
- D $7\frac{1}{2}$
- E 10
- F 15
- G $16\frac{2}{3}$

$n_Q = 3n_P$

$\alpha_Q = 10^\circ + \alpha_P$

$$\frac{(n_Q - 2) \cdot 180^\circ}{n_Q} = 10^\circ + \frac{(n_P - 2) \cdot 180^\circ}{n_P}$$

$$\frac{(3n_P - 2) \cdot 180^\circ}{3n_P} = 10 + \frac{180n_P - 360}{n_P}$$

$$180 - \frac{120}{n_P} = 10 + 180 - \frac{360}{n_P}$$

$$\frac{240}{n_P} = 10 \Rightarrow n_P = 24$$

$n_Q = 3 \cdot 24 = 72$

$\alpha_Q = 175^\circ$

$n_R = 2n_Q = 144$

$\alpha_R = 177.5^\circ$

$\alpha_Q - \alpha_R = 2.5^\circ$

19 The point $(-1, 5)$ is translated to the point $(3, 2)$ by two successive translations.

The first translation is by the vector $\begin{pmatrix} 3p \\ -4p \end{pmatrix}$

The second translation is by the vector $\begin{pmatrix} q \\ -2q \end{pmatrix}$

What is the value of $p + q$?

- A -14
- B -7
- C -5
- D -1
- E 1
- F 5
- G 7
- H 14

$$\begin{pmatrix} -1 \\ 5 \end{pmatrix} + \begin{pmatrix} 3p \\ -4p \end{pmatrix} + \begin{pmatrix} q \\ -2q \end{pmatrix} = \begin{pmatrix} 3 \\ 2 \end{pmatrix}$$

$$\left. \begin{aligned} -1 + 3p + q &= 3 \Rightarrow 3p + q = 4 \\ 5 - 4p - 2q &= 2 \Rightarrow -4p - 2q = -3 \end{aligned} \right\} + \begin{aligned} 3p + q - 4p - 2q &= 4 - 3 \\ -p - q &= 1 \\ p + q &= -1 \end{aligned}$$

20 Consider the graphs of the form

$$y = x^2 + 2ax + a$$

What is the complete range of values of a for which the minimum point of the graph lies above the x -axis?

- A There are no values of a
- B $a < 0$
- C $0 < a < 1$
- D $-1 < a < 1$
- E $a < -1$ or $a > 1$
- F $a < 0$ or $a > 1$
- G a can take any value

MINIMUM $\frac{dy}{dx} = 0 = 2x + 2a$

$$x_{\text{MIN}} = -a$$

ABOVE x -AXIS MEANS $y_{\text{MIN}} > 0$

$$y_{\text{MIN}} = x_{\text{MIN}}^2 + 2ax_{\text{MIN}} + a = a^2 - 2a^2 + a = a - a^2$$

$$a - a^2 > 0$$

$$a(1 - a) > 0$$

ROOTS $a = 0, 1$

$$a - a^2 > 0 \text{ WHEN}$$

$$0 < a < 1$$

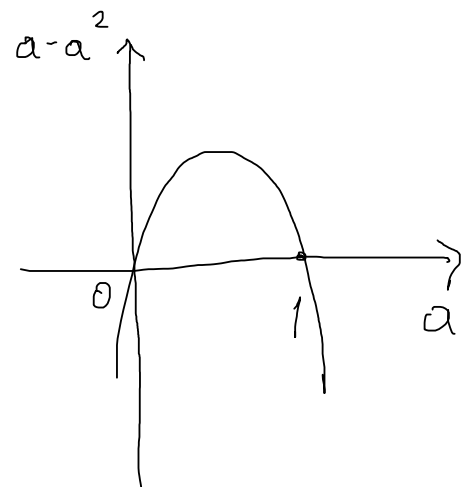

PART B Physics

- 21 There is a constant current in a conducting wire. A charge of 20 C passes through the wire in 1.5 minutes.

An 18 cm straight section of this wire lies in a uniform magnetic field. This section of wire is perpendicular to the direction of the field. The magnetic field strength is 0.15 T.

What is the magnitude of the magnetic force on this section of wire?

(A) 0.0060 N

B 0.36 N

C 0.60 N

D 0.81 N

E 36 N

F 49 N

G 81 N

H 4900 N

$$I = \frac{\Delta Q}{\Delta t} = \frac{20}{15 \cdot 60} = \frac{20}{90} = \frac{2}{9} \text{ A}$$

$$F_{\text{LORENTZ}} = Q v B \sin \theta$$

$$= Q \frac{l}{t} B \sin \theta$$

$$= I \cdot l B \sin \theta$$

$$= \frac{2}{9} \cdot 0.18 \cdot 0.15 \cdot \sin 90^\circ = 0.006 \text{ N}$$

- 22 A rider on a rollercoaster moves very quickly towards a solid wall. While moving, the rider shouts, and hears an echo of the shout from the wall. The echo is quieter than the original shout.

How do the amplitude and frequency of the echo heard by the rider compare to the amplitude and frequency of the original shout?

	<i>amplitude</i>	<i>frequency</i>
A	lower	lower
B	lower	unchanged
(C)	lower	higher
D	unchanged	lower
E	unchanged	higher
F	higher	lower
G	higher	unchanged
H	higher	higher

The volume of sound is proportional to its amplitude. If the echo is quieter, it means its amplitude is lower.

To determine the frequency change, consider Doppler's effect.

Initially, the rider shouts, acting as the source of the sound wave, while the wall acts as the receiver of the wave. Since the source is approaching the receiver, the waves get pushed closer together, so the frequency at the wall increases.

When the sound gets reflected off the wall, the wall starts acting as the source, and the rider as the receiver. Now, the receiver is approaching the source, so the received frequency increases again.

- 23 The diagram shows a system consisting of two large copper tanks of water connected to each other by a solid cylindrical copper bar.

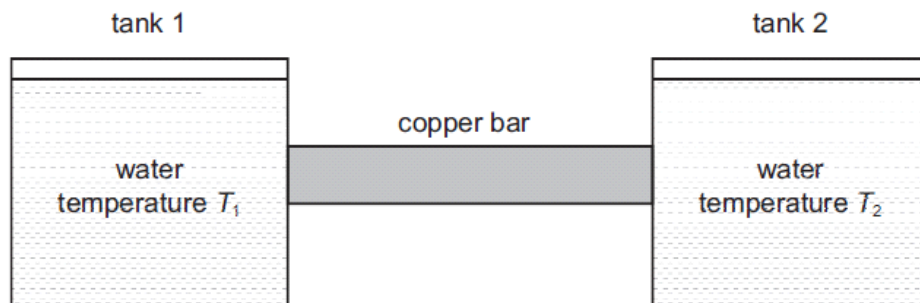

The temperature of the water in tank 1 is T_1 . The water in tank 2 is at a higher temperature T_2 .

The following four statements list changes that can be made, independently, to the system. At all times $T_1 < T_2$.

- 1 increase temperature T_1
- 2 increase temperature T_2
- 3 increase the length of the copper bar
- 4 increase the diameter of the copper bar

Which two changes each independently result in an increase in the rate of conduction of thermal energy along the copper bar?

- A 1 and 2
B 1 and 3
C 1 and 4
D 2 and 3
E 2 and 4
F 3 and 4

The rate of conduction is proportional to the temperature difference between the tanks. Since $T_2 > T_1$:

1) increasing T_1 would increase the temperature difference, therefore increasing the rate of conduction

2) increasing T_2 would increase the temperature difference, increasing the rate of conduction.

3) The rate of conduction is inversely proportional to the length of the wire (the longer it is, the further apart the tanks are), so increasing its length would decrease the rate of conduction.

4) The rate of conduction is proportional to the area of the contact. Increasing the diameter of the copper bar would therefore increase the rate of conduction.

- 24 Two identical resistors are connected in parallel to a 6.0 V battery. The two resistors dissipate a total power of 0.15 W.

One of these resistors is removed from the circuit and connected to a 12 V battery.

How much charge passes through this resistor in 6.0 minutes?

2

- A 0.025 C
- B 0.050 C
- C 0.15 C
- D 0.30 C
- E 0.75 C
- F 1.5 C
- G 9.0 C
- H 18 C

$$P_{TOTAL} = \frac{V_{TOTAL}^2}{R_{TOTAL}} \Rightarrow R_{TOTAL} = \frac{V_{TOTAL}^2}{P_{TOTAL}} = \frac{6^2}{0.15} = 240 \Omega$$

$$\text{RESISTORS IN PARALLEL} \Rightarrow \frac{1}{R_{TOTAL}} = \frac{1}{R_1} + \frac{1}{R_1} = \frac{2}{R_1}$$

$$R_1 = 2 R_{TOTAL} = 480 \Omega$$

IF R_1 CONNECTED TO 12V, USE $I = \frac{V}{R} = \frac{12}{480} = \frac{1}{40} \text{ A}$

$$I = \frac{\Delta Q}{\Delta t} \Rightarrow \Delta Q = I \Delta t = \frac{1}{40} \cdot 6 \cdot 60 = 9 \text{ C}$$

- 25 A small piece of space debris of mass 0.10 g strikes the International Space Station at a relative speed of 15 000 m s^{-1} .

The piece of debris comes to rest relative to the space station in a time of 0.010 s.

What is the average force exerted on the space station by the piece of debris during this time?

- A 0.0010 N
- B 1.0 N
- C 1.5 N
- D 100 N
- E 150 N
- F 1500 N

$$P_{INITIAL} = mv$$

$$P_{FINAL} = 0 \text{ (AT REST)}$$

$$\text{CHANGE IN MOMENTUM } \Delta p = mv$$

I took the absolute value of the change in momentum (no negative sign), because the direction of the force is not asked for in the problem.

$$\text{IMPULSE} = I = F \cdot \Delta t$$

$$I = \Delta p$$

$$F \cdot \Delta t = mv$$

$$F = \frac{mv}{\Delta t} = \frac{0.1 \cdot 10^{-3} \cdot 15000}{0.01} = 150 \text{ N}$$

- 26 A block of mass 6.0 kg is pushed along a rough horizontal surface by a constant force of 8.0 N. The block accelerates uniformly from rest. After 4.0 s its velocity is 2.0 m s^{-1} .

How much work is done against resistive forces during this 4.0 s?

- A 12 J
B 20 J
C 24 J
D 32 J
E 40 J
F 64 J

$$a = \frac{\Delta v}{\Delta t} = \frac{2}{4} = 0.5 \text{ m s}^{-2}$$

$$s = \frac{1}{2} a t^2 = \frac{1}{2} \cdot 0.5 \cdot 4^2 = 4 \text{ m}$$

The work done against resistive forces is effectively heat loss due to friction.

The total work gets converted to kinetic energy of the block and heat.

$$W_{\text{TOTAL}} = E_K + W_{\text{HEAT}}$$

$$F \cdot s = \frac{1}{2} m v^2 + W_{\text{HEAT}}$$

$$8 \cdot 4 = \frac{1}{2} \cdot 6 \cdot 2^2 + W_{\text{HEAT}}$$

$$\Rightarrow W_{\text{HEAT}} = 20 \text{ J}$$

- 27 Ultrasound is used to find a crack inside a cuboid block of metal. An ultrasound probe is held in contact with the top surface of the metal block and perpendicular to the surface. A short pulse of ultrasound is sent into the metal block at time $t = 0$ ms and reflects from both the crack and the bottom surface of the metal block.

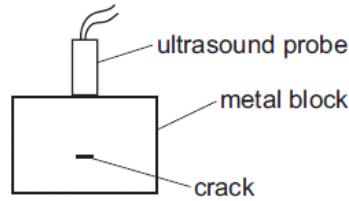

The times between the emission of the ultrasound pulse and the return of the reflections to the probe, and the strengths of the reflected pulses, are measured. The results are shown on the graph.

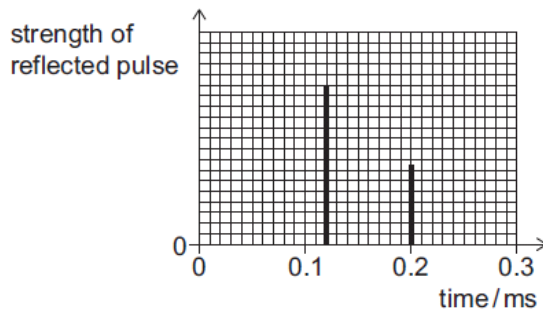

The speed of ultrasound in the metal is 5000 ms^{-1} .

What is the distance between the **bottom surface** of the metal block and the crack?

- A 0.2 m
- B 0.3 m
- C 0.4 m
- D 0.5 m
- E 0.6 m
- F 1.0 m

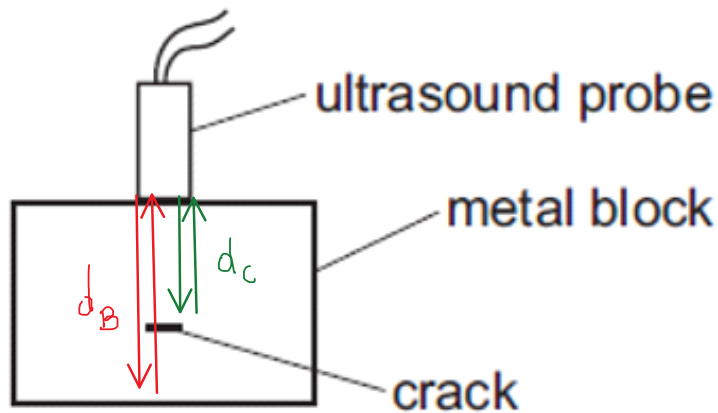

On the way to the crack, the ultrasound wave travels there and back, therefore a distance of $2d_c$. It is received first, at $t_1 = 0.12$ ms, because the crack is closer to the probe.

$$2d_c = v \cdot t_1 \Rightarrow d_c = \frac{v t_1}{2}$$

Similarly, on the way to the bottom, the ultrasound wave travels to the bottom and back to the top - a distance of $2d_B$. It is received second, at $t_2 = 0.20$ ms, because the bottom is further away from the probe than the crack.

$$2d_B = v \cdot t_2 \Rightarrow d_B = \frac{v t_2}{2}$$

The distance between the crack and the bottom is
$$\Delta d = d_B - d_c = \frac{v}{2} (t_2 - t_1) = \frac{5000}{2} \cdot (0.20 - 0.12) \cdot 10^{-3} = 0.2 \text{ m}$$

28 Power is supplied to an electric motor at 0.800 kW.

The motor has an efficiency of 60% and is switched on for half an hour.

How much energy is **wasted** during this time?

- A 0.160 J
- B 0.240 J
- C 160 J
- D 240 J
- E 576 J
- F 864 J
- G 576 000 J**
- H 864 000 J

$$P_{TOTAL} = \frac{W_{TOTAL}}{\Delta t}$$

$$\Rightarrow W_{TOTAL} = P_{TOTAL} \Delta t = 0.8 \cdot 10^3 \cdot 0.5 \cdot 3600 = 1.44 \cdot 10^6 \text{ J}$$

$$EFFICIENCY = \frac{W_{USEFUL}}{W_{TOTAL}}$$

$$\Rightarrow W_{USEFUL} = 0.6 \cdot 1.44 \cdot 10^6 \text{ J} = 864 000 \text{ J}$$

$$W_{LOST} = W_{TOTAL} - W_{USEFUL} = 576 000 \text{ J}$$

29 The diagram shows a circuit that includes two ammeters and a resistor R.

The readings on the ammeters are shown.

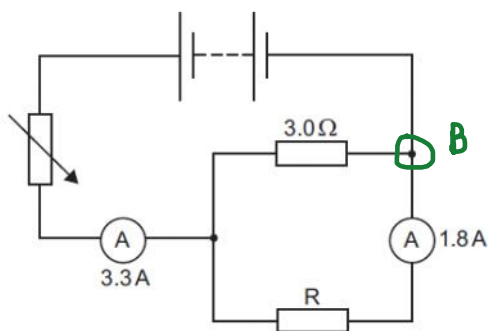

Very mean how they drew this circuit!

Let's redraw it - just make sure that B is the branching point of the parallel and then simplify.

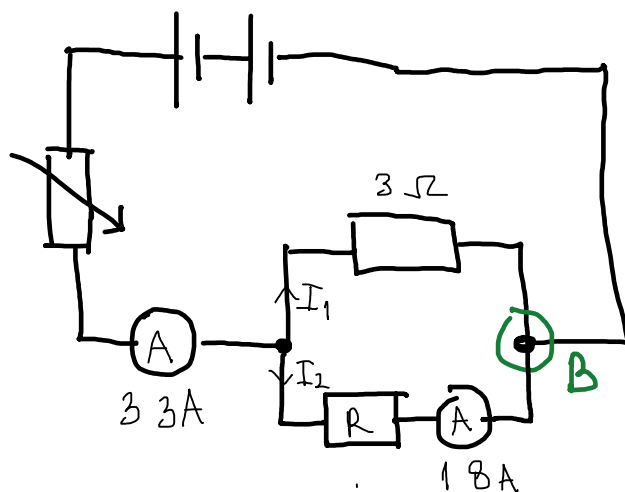

What is the resistance of resistor R?

- A 0.40 Ω
- B 2.5 Ω**
- C 3.0 Ω
- D 3.6 Ω
- E 5.5 Ω
- F 8.5 Ω

After redrawing, it is clear that the bottom ammeter measures I_2 - the current passing to R.

$$I_{TOTAL} = I_1 + I_2$$

$$3.3 = I_1 + 1.8$$

$$I_1 = 1.5 \text{ A}$$

Since the two resistors are connected in parallel, the voltage across them needs to be the same.

$$V_1 = V_2$$

$$I_1 \cdot R_1 = I_2 \cdot R$$

$$1.5 \cdot 3 = 1.8 \cdot R \Rightarrow R = 2.5 \Omega$$

30 The graph shows potential difference plotted against current for a filament lamp and a resistor.

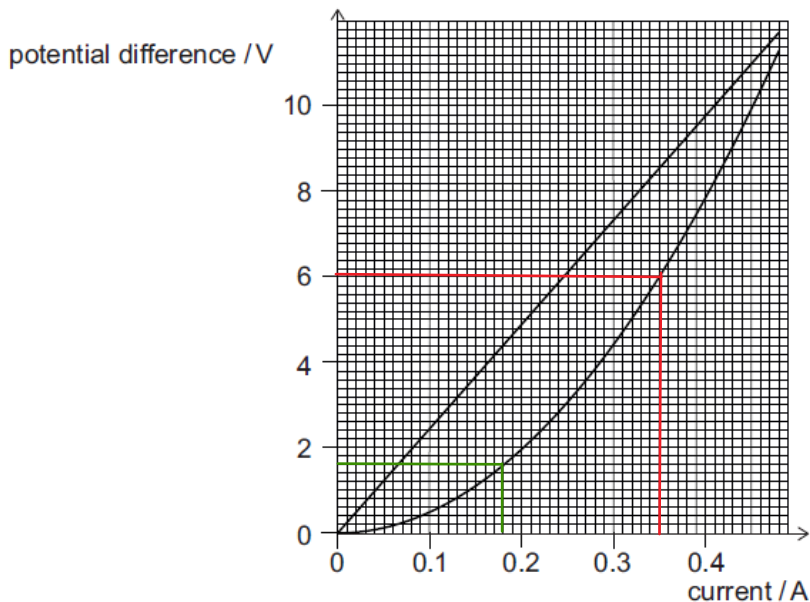

The lamp and the resistor are connected in parallel with each other to a 6.0 V power supply and the current in the lamp, I , is recorded.

In a second circuit, the lamp and the resistor are now connected in series with each other to the same power supply, and the current in the resistor is 0.18 A. The potential difference across the lamp, V , is recorded.

What are the values of I in the first circuit and V in the second circuit?

	I / A	V / V
A	0.25	1.6
B	0.25	3.0
C	0.25	4.4
D	0.35	1.6
E	0.35	3.0
F	0.35	4.4

The straight line corresponds to the resistor, because it follows Ohm's law perfectly.

The curved line corresponds to the filament lamp, because filament lamps are not Ohmic resistors.

In the 1st circuit, they are connected in parallel, so both of them are at the same voltage of 6 V. Reading off the value from the graph, at the voltage of 6V, the current in the lamp is 3.5 A.

In the 2nd circuit, they are connected in series, so the same current of 0.18 A goes through both of them. Reading off the value from the graph, at the current of 0.18 A, the voltage across the lamp is 1.6 V.

- 31 A child is bouncing a ball of mass 0.16 kg vertically up and down on a bat. Each time the ball hits the bat the duration of the contact is 0.20 s. The speed of the ball immediately before hitting the bat and immediately after it loses contact with the bat is 4.0 m s^{-1} .

What is the average contact force between the bat and the ball during each collision?

(gravitational field strength = 10 N kg^{-1})

$$v_1 = -4 \text{ m/s}$$

$$v_2 = +4 \text{ m/s}$$

A 1.6 N

B 3.2 N

C 4.8 N

D 6.4 N

E 8.0 N

→ CONSIDER IMPULSE

$$I = \Delta p$$

$$F \cdot \Delta t = m v_2 - m v_1$$

$$F = \frac{m(v_2 - v_1)}{\Delta t} = \frac{0.16 \cdot (4 - (-4))}{0.2} = 6.4 \text{ N}$$

$$F_{\text{TOTAL}} = F + W = F + mg = 6.4 \text{ N} + 1.6 \text{ N} = 8 \text{ N}$$

- 32 A transverse wave on a string has a speed of 500 m s^{-1} .

The horizontal distance between two points P and Q on the wave is 4.0 m, as shown in the diagram.

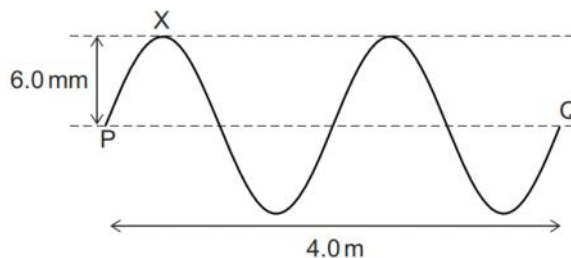

At time $t = 0 \text{ ms}$, point X on the string is at its maximum displacement of 6.0 mm above equilibrium.

What is the displacement of point X at time $t = 7.0 \text{ ms}$?

A 6.0 mm above equilibrium

B between 0 mm and 6.0 mm above equilibrium

C 0 mm

D between 0 mm and 6.0 mm below equilibrium

E 6.0 mm below equilibrium

$$PQ = 2\lambda$$

$$\Rightarrow \lambda = 2 \text{ m}$$

$$v = \frac{\lambda}{T}$$

$$\Rightarrow T = \frac{\lambda}{v} = \frac{2}{500} = 4 \text{ ms}$$

$$t = 7 \text{ ms} = \frac{7}{4} T = 1T + \frac{3}{4} T$$

After 7 ms, the wave makes one full period plus three quarters of a period.

After one period, the point X is back to 6 mm above the equilibrium.

Now comes the interesting part:

- after another quarter, the point X is in the equilibrium at 0 mm.
- after two quarters, it is at the opposite point at 6 mm below the equilibrium.
- after three quarters, it is again in the equilibrium at 0 mm.

- 33 A neutral atom Q of a particular element contains a total of 20 particles (protons, neutrons and electrons).

The table shows information about the number of particles and relative charges of four atoms or ions W, X, Y and Z.

<i>atom or ion</i>	<i>number of particles</i>	<i>relative charge of atom or ion</i>
W	21	0
X	21	-1
Y	20	+1
Z	22	0

Which of these atoms or ions could be of a different isotope to Q but of the same element as Q?

- A W only
- B X only
- C Z only
- D X and Z only
- E W and Y only
- F W, X and Y only
- G W, Y and Z only
- H X, Y and Z only

The same element must have the same number of protons.

Isotopes have the same number of protons but a different number of neutrons.

W has one particle more than Q and it is neutral, so it is an isotope of Q with an extra neutron.

X also has one particle more than Q. Since it is a negative ion, it has an extra electron. This means X is a negative ion of Q, but not an isotope of Q.

Y is a positive ion, so it has an electron fewer than Q. Since Y has the same number of particles as Q, it must have an extra neutron compared to Q, so it is an isotope of Q.

Z has two particles more than Q and is neutral, so it is an isotope of Q with two extra neutrons.

34 Radioactive isotope X undergoes a single beta (β^-) decay to form the stable isotope Y.

A sample consists only of X and Y. The graph shows how the mass of Y present in the sample varies with time. After a long time, the mass of Y in the sample becomes a constant 50 g.

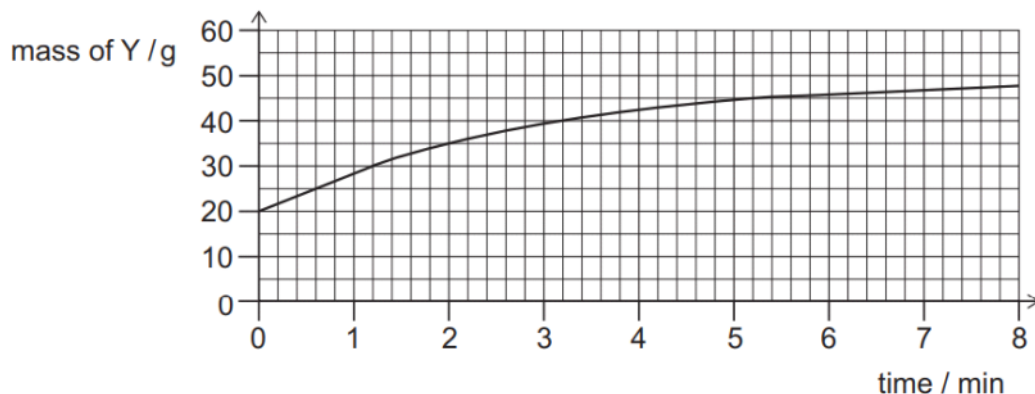

What is the half-life of X?

- A 0.6 minutes
- B 1.2 minutes
- C 2.0 minutes**
- D 3.2 minutes
- E 4.0 minutes
- F 5.2 minutes

The initial mass of Y is 20 g and its final mass is 50 g, which means that 30 g of X decayed into Y. Therefore, the initial mass of X is 30 g.

After one half-life, one half of X, i.e. 15 g, decayed into Y.

This means there are $20 + 15 = 35$ g of Y after one half-life.

Reading off the values from the graph, there is 35 g of Y after 2 min, so the half-life is 2 min.

- 35 A piece of metal of mass 50 g is at thermal equilibrium in a hot liquid at temperature T .
The metal is removed from the liquid and immediately placed in 100 g of water that is at 20°C .
The water is stirred and reaches a final temperature of 26°C .

<i>material</i>	<i>specific heat capacity / $\text{J kg}^{-1} \text{ }^\circ\text{C}^{-1}$</i>
hot liquid	2000
metal	350
water	4200

What is the temperature T of the hot liquid?

(Assume that heat transfers to or from the surroundings are negligible.)

A 38°C

B 51°C

C 150°C

D 170°C

E 480°C

Heat lost by metal = heat received by water.

$$M_M \cdot C_M \cdot \Delta T_M = M_W \cdot C_W \cdot \Delta T_W$$

$$0.05 \cdot 350 \cdot (T - 26) = 0.1 \cdot 4200 \cdot (26 - 20)$$

$$T = 170^\circ\text{C}$$

- 36 A bar magnet is placed at position X close to one end of a coil and on the axis of the coil as shown.

The graph shows how the velocity of the magnet varies as it is then moved rapidly to position Y and back to position X.

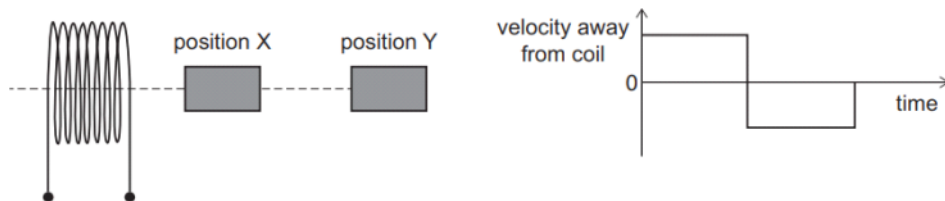

The magnetic field of the bar magnet still affects the coil when the magnet is at position Y.

Which graph represents how the induced voltage in the coil changes as the magnet moves?

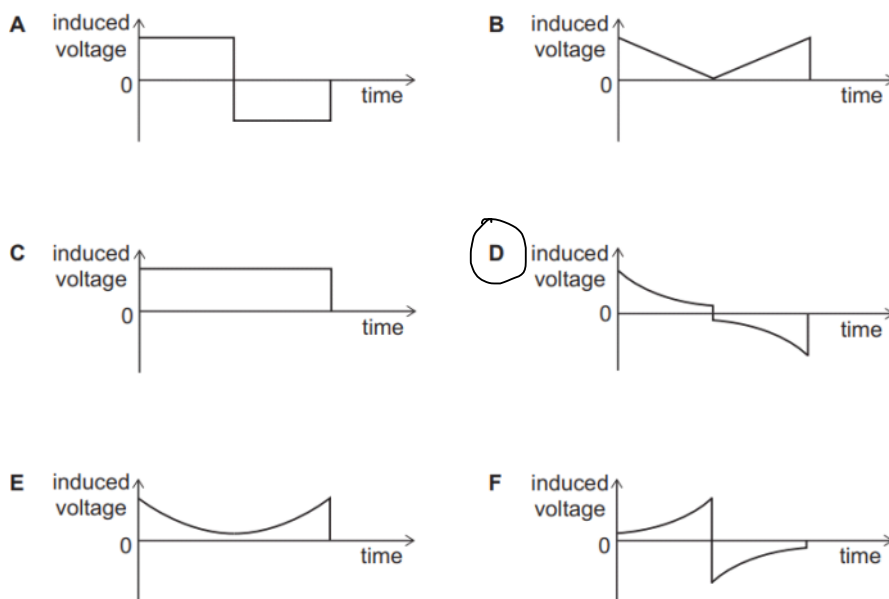

FARADAY'S LAW:

$$\mathcal{E} = - \frac{\Delta \Phi}{\Delta t} = - \frac{\Delta (B \cdot A)}{\Delta t} = - \frac{B \cdot \Delta A}{\Delta t} = - \frac{B \cdot l \cdot \Delta s}{\Delta t} = - B l v$$

WHERE l = MAGNET LENGTH & $l \Delta s$ = AREA IT SWEEPS WHEN MOVING

$$\mathcal{E} = - B l v$$

$$\mathcal{E} \propto B \quad \text{AND} \quad \mathcal{E} \propto v$$

The induced voltage is proportional to B and v .

B drops quadratically away from the coil (Bio-Savart law), and v is constant.

Therefore, the magnitude of induced voltage **decreases quadratically** when the magnet is **moving away** from the coil and **increases quadratically** when the magnet is **approaching** the coil.

Graphs E and D show such behavior. Since the induced voltage depends of v , when v switches the sign, the voltage must also change the sign, which corresponds to Graph D.

Watch the video on my-academics.com/nsaa for a detailed explanation of Faraday's law.

- 37 A small slider of mass 30 g is at rest near the bottom of a frictionless slope and in contact with a light uncompressed spring as shown.

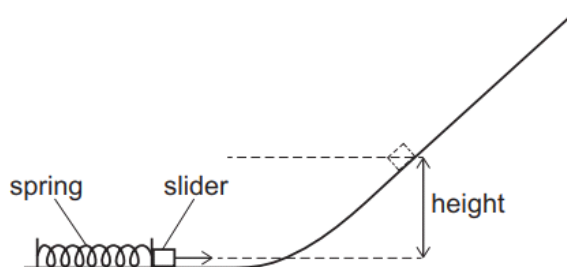

[diagram not to scale]

The spring is compressed by 5.0 cm and the slider remains in contact with it.

The spring is released and causes the slider to rise up the slope to a maximum vertical height of 20 cm.

The slider is replaced with one of mass 20 g.

The spring is now compressed by 15 cm, and the new slider remains in contact with it.

To what maximum vertical height does this new slider rise after it is released?

(the spring obeys Hooke's law; assume that air resistance is negligible)

- A 40 cm
- B 60 cm
- C 90 cm
- D 120 cm
- E 180 cm
- F 270 cm**

Elastic energy = gravitational potential energy

$$\frac{1}{2} k \Delta x_1^2 = m_1 g h_1$$

$$k = \frac{2m_1 g h_1}{\Delta x_1^2} = \frac{2 \cdot 0.03 \cdot 10 \cdot 0.2}{0.05^2} = 48 \text{ N/m}$$

$$m_2 g h_2 = \frac{1}{2} k \Delta x_2^2$$

$$h_2 = \frac{k \Delta x_2^2}{2m_2 g} = \frac{48 \cdot 0.15^2}{2 \cdot 0.02 \cdot 10} = 2.7 \text{ m}$$

- 38 A tall, smooth cylinder contains air at atmospheric pressure of $1.00 \times 10^5 \text{ Pa}$. The density of the air in the cylinder is 1.20 kg m^{-3} .

A heavy piston is now placed in the top of the cylinder and allowed to fall slowly downwards, compressing the air until the piston rests in equilibrium.

The mass of the piston is 50.0 kg and its cross-sectional area is 0.0200 m^2 .

What is the density of the air in the cylinder when the piston rests in equilibrium?

(gravitational field strength = 10 N kg^{-1} ; assume that the air behaves as an ideal gas and that the temperature remains constant)

- A 0.960 kg m^{-3}
- B 1.20 kg m^{-3}
- C 1.25 kg m^{-3}
- D 1.28 kg m^{-3}
- E 1.50 kg m^{-3}
- F 4.80 kg m^{-3}

The piston exerts extra pressure on the gas due to its weight.

$$\Delta p = \frac{F}{A} = \frac{mg}{A} = \frac{50 \cdot 10}{0.02} = 25000 \text{ Pa}$$

$$p_2 = p_1 + \Delta p = 100000 + 25000 = 125000 \text{ Pa}$$

Ideal gas equation:

$$pV = nRT$$

$$pV = \frac{N}{N_A} RT$$

N = number of molecules
 N_A = Avogadro's constant.

USE $m = N \cdot m_1$

m = total mass
 m_1 = mass of one molecule

$$pV = \frac{m/m_1}{N_A} RT$$

$$p = \frac{m}{V N_A m_1} RT$$

$$p = \frac{\rho}{N_A m_1} RT$$

$$\Rightarrow p \propto \rho$$

$$\frac{\rho_2}{\rho_1} = \frac{p_2}{p_1}$$

$$\rho_2 = \frac{125000}{100000} \cdot 1.2 = 1.5 \text{ kg m}^{-3}$$

- 39 There are two types of earthquake waves, called P-waves and S-waves.

When an earthquake occurs, both types of wave are produced at the same time and follow the same path.

The P-waves travel outwards from the source at 5.0 km s^{-1} and the S-waves travel out at 3.0 km s^{-1} .

A seismic monitoring station detects the P-waves 30 s before the S-waves.

How far have the waves travelled from the source of the earthquake to reach the seismic monitoring station?

- A 60 km
- B 90 km
- C 135 km
- D 150 km
- E 225 km

$$t_s = t_p + 30 \text{ s}$$

$$S = v_p t_p$$

$$S = v_s t_s$$

$$v_p t_p = v_s t_s$$

$$5 t_p = 3 (t_p + 30)$$

$$\Rightarrow t_p = 45 \text{ s}$$

$$S = v_p \cdot t_p = 5 \text{ km/s} \cdot 45 \text{ s} = 225 \text{ km}$$

- 40 A solid cuboid has a mass of 32 kg and a density of 4.0 g cm^{-3} .

Faces 1, 2 and 3 of the cuboid have different areas.

When the cuboid rests on one of these faces on a flat horizontal surface, the pressure on the surface due to the cuboid is 1.6 N cm^{-2} .

When it rests on another of these faces, the pressure on the surface due to the cuboid is 0.80 N cm^{-2} .

What is the pressure on the surface due to the cuboid when it rests on the third of these faces?

(gravitational field strength = 10 N kg^{-1})

(A) 0.40 N cm^{-2}

B 1.2 N cm^{-2}

C 3.2 N cm^{-2}

D 6.4 N cm^{-2}

E 8.0 N cm^{-2}

$$p = \frac{F}{A} = \frac{mg}{A}$$

$$\Rightarrow A = \frac{mg}{p}$$

$$A_1 = \frac{32 \cdot 10 \text{ N}}{1.6 \text{ N/cm}^2} = 200 \text{ cm}^2$$

$$A_2 = \frac{32 \cdot 10 \text{ N}}{0.8 \text{ N/cm}^2} = 400 \text{ cm}^2$$

$$m = \rho \cdot V$$

$$\Rightarrow V = \frac{m}{\rho} = \frac{32000 \text{ g}}{4 \text{ g/cm}^3} = 8000 \text{ cm}^3$$

Let a, b, c be the sides of the cuboid.

$$\left. \begin{array}{l} V = abc \\ A_1 = ab \end{array} \right\} V = A_1 \cdot c \Rightarrow c = \frac{V}{A_1} = \frac{8000}{200} = 40 \text{ cm}$$

$$\left. \begin{array}{l} V = abc \\ A_2 = ac \end{array} \right\} V = A_2 \cdot b \Rightarrow b = \frac{V}{A_2} = \frac{8000}{400} = 20 \text{ cm}$$

$$A_3 = b \cdot c = 40 \cdot 20 = 800 \text{ cm}^2$$

$$p_3 = \frac{mg}{A_3} = \frac{32 \cdot 10}{800} = 0.4 \text{ N/cm}^2$$